

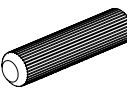

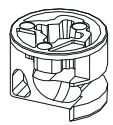







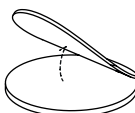
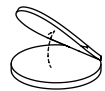
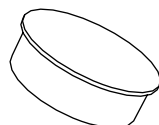
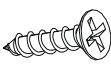
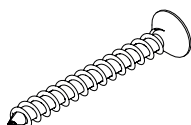
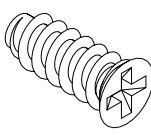
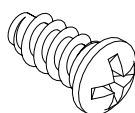

DALLAS 09

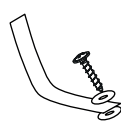
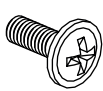
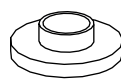
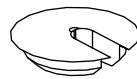
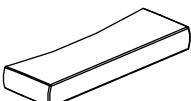
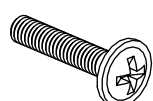
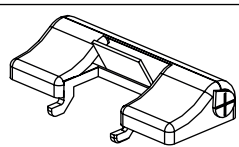
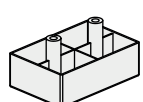
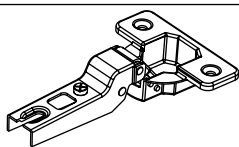
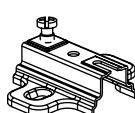
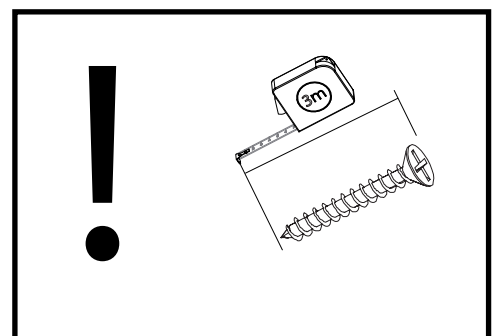
<p>GW1 x 5 1,4x25</p> 	<p>K1 x 16 8x32</p> 	<p>B2 x 16 h-12</p> 
<p>ZJ1 x 16 L-43</p> 	<p>ZS2 x 16 Ø20</p> 	<p>ZS1 x 17 Ø13</p> 
<p>ZA35 x 4 Ø35</p> 	<p>WT1 x 20 3,5x15</p> 	<p>WT38 x 10 4x45</p> 
<p>WE3 x 6 ES6,3x16KB/m</p> 	<p>WE2 x 8 EK6,3x13B</p> 	<p>PO3 x 8 Ø5</p> 
<p>SP x 8</p> 	<p>TUD1 x 6 6,1x8x12,2x2x4</p> 	<p>KT35 x 3 35x35</p> 
<p>PZK x 1</p> 	<p>WT39 x 2 4x12M</p> 	<p>TUD4 x 2</p> 
<p>ZOH x 2 Ø20</p> 	<p>UCH x 2</p> 	<p>WT19 x 2 4x22M</p> 
<p>SDO x 2</p> 	<p>ST5 x 4 60x40x20</p> 	<p>ZP12 x 4 1/2</p> 
<p>PK4 x 4 H-4</p> 		

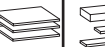
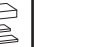

DALLAS 09

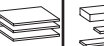
	CODE				
1	Dallas09_02	596	408	1	1/3
2	Dallas09_05	481	80	2	1/3
3	4SZKL-4NR27	1148	477	1	1/3
4	Dallas09_10	488	185	1	1/3
5	Dallas0209_01	481	100	1	3/3
6	Dallas09_03	1954	407	1	2/3
7	Dallas09_06	1953,5	80	1	2/3
8	4SZKL-5NR40	536	273	2	2/3
9	Dallas09HDF_01	1966	547	1	2/3
10	Dallas09_04	1954	407	1	2/3

	CODE				
11	Dallas09_07	1953,5	80	1	2/3
12	Dallas09_01	596	408	1	1/3
13	Dallas09_08	537	342	1	1/3
14	Dallas09_11	488	185	1	1/3
15	Dallas09_09	488	359	1	1/3

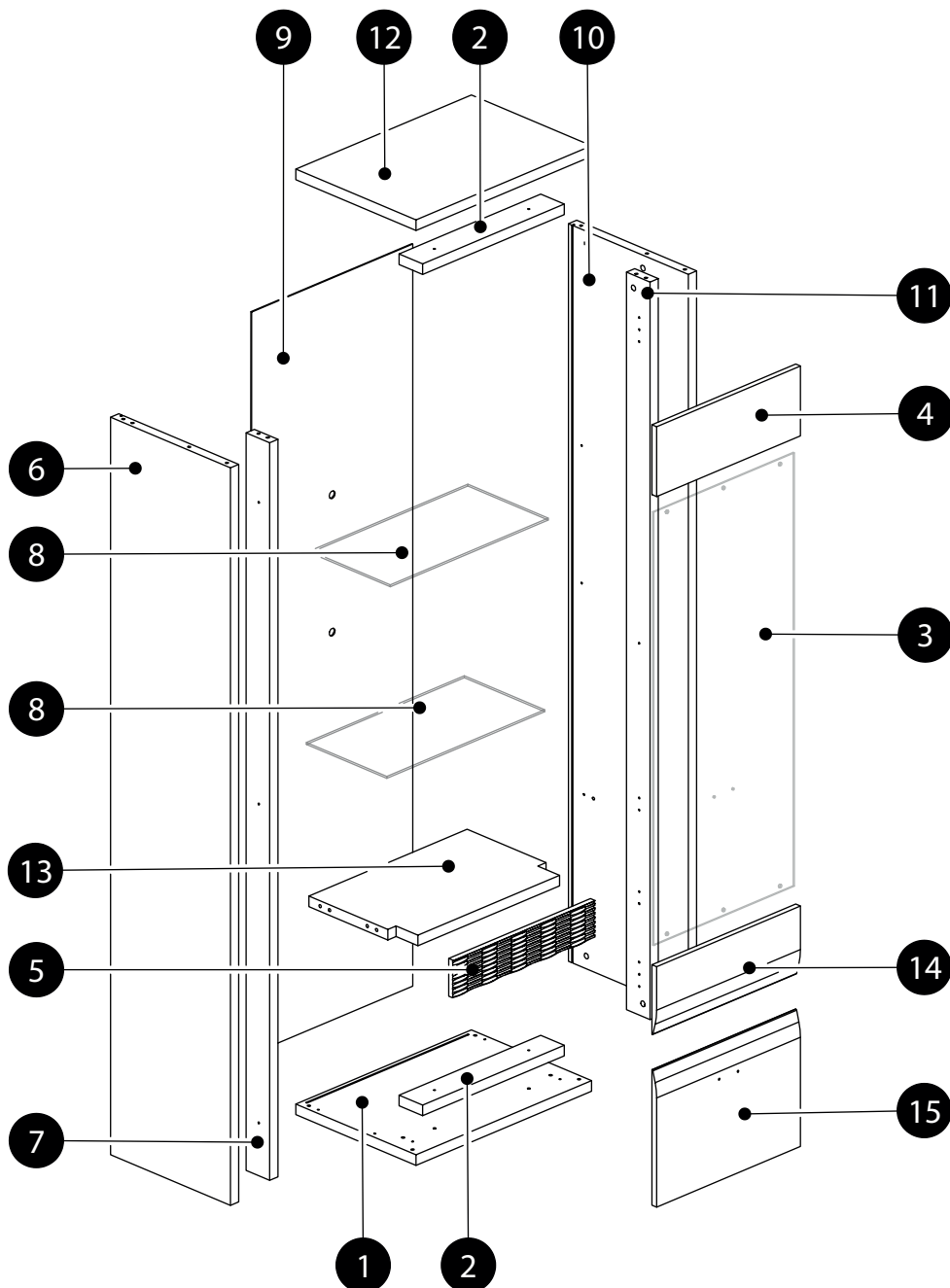

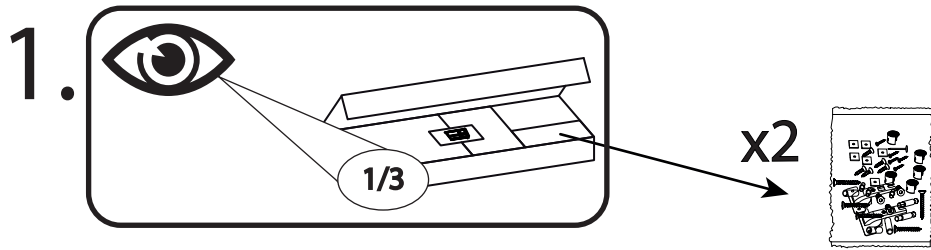

2.

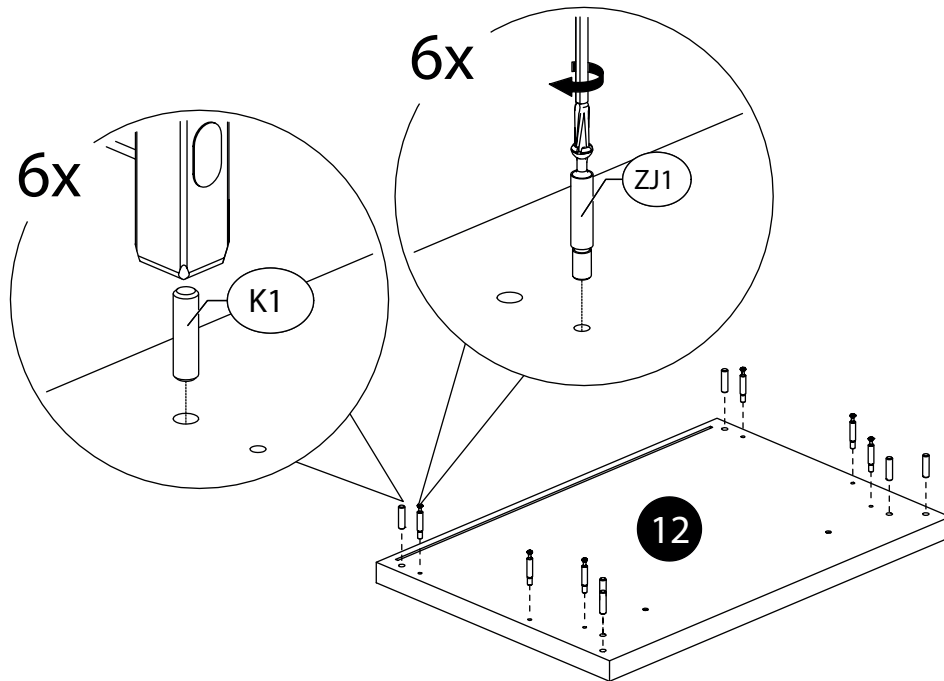

3.

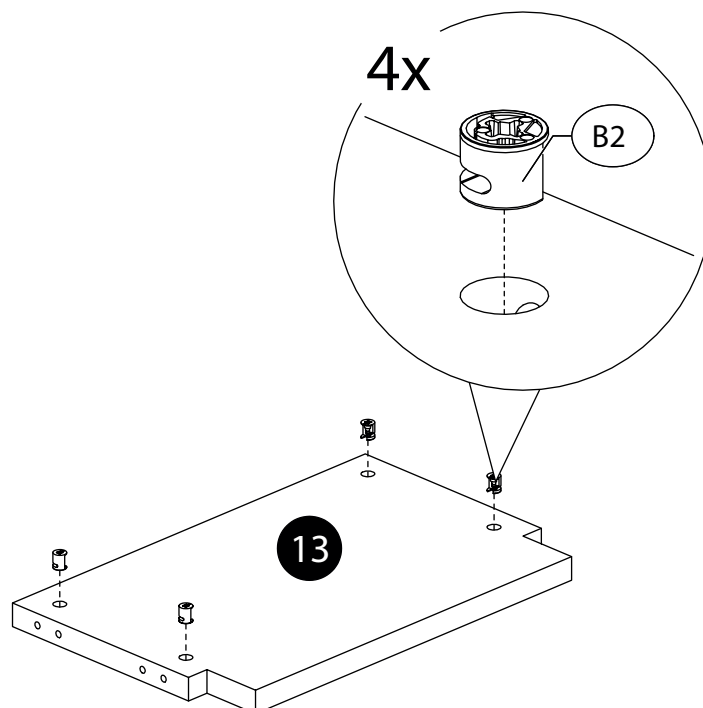

4.

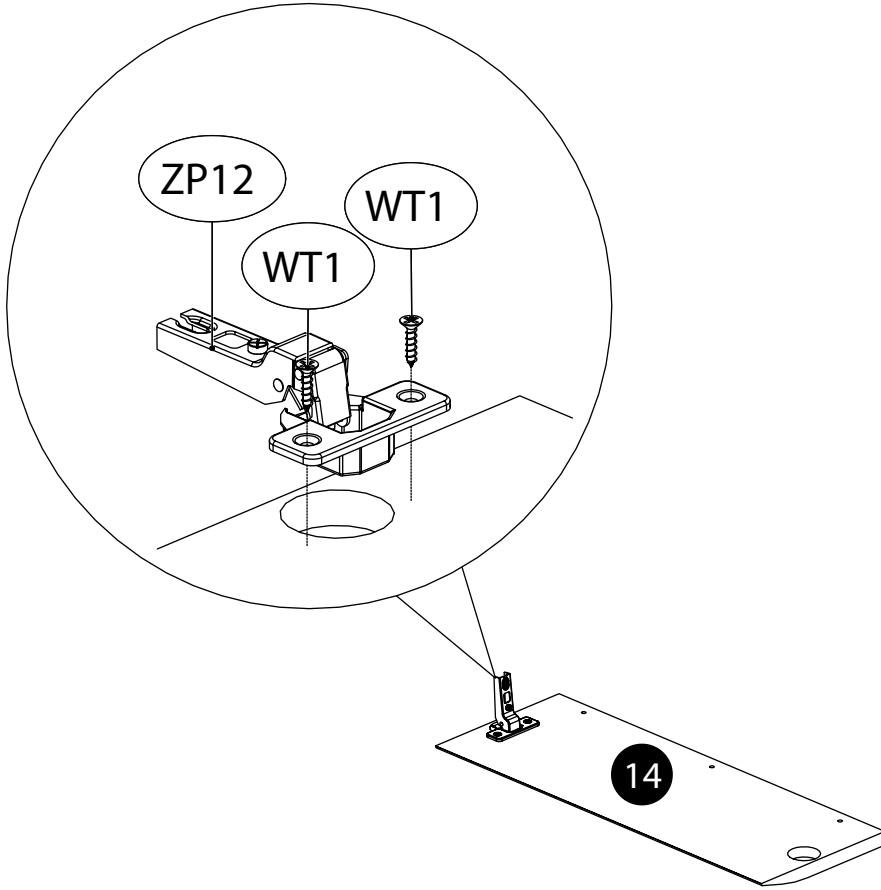

5.

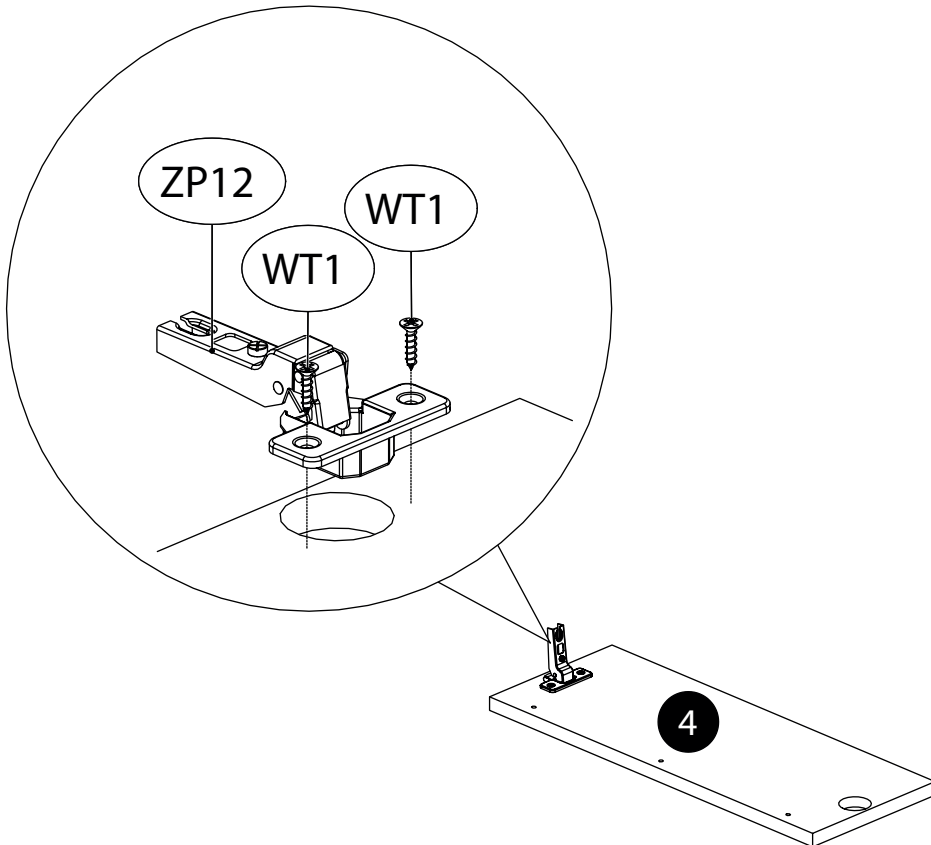

6.

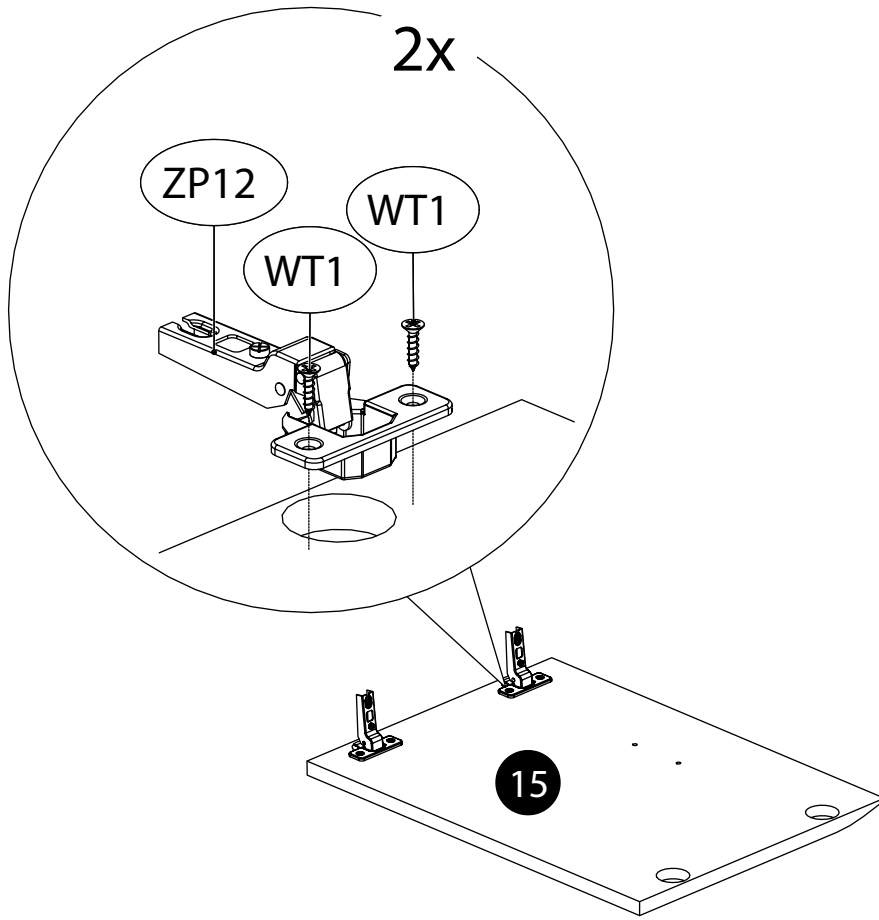

7.

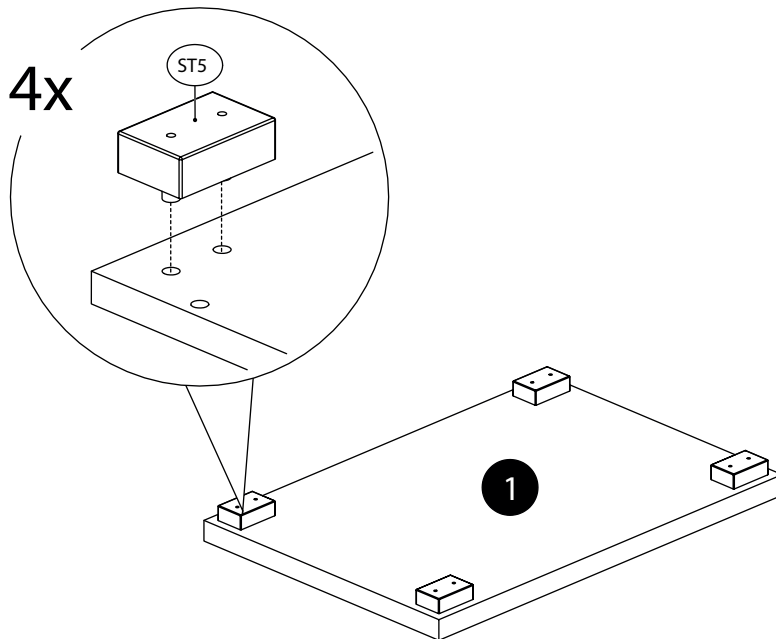

8.

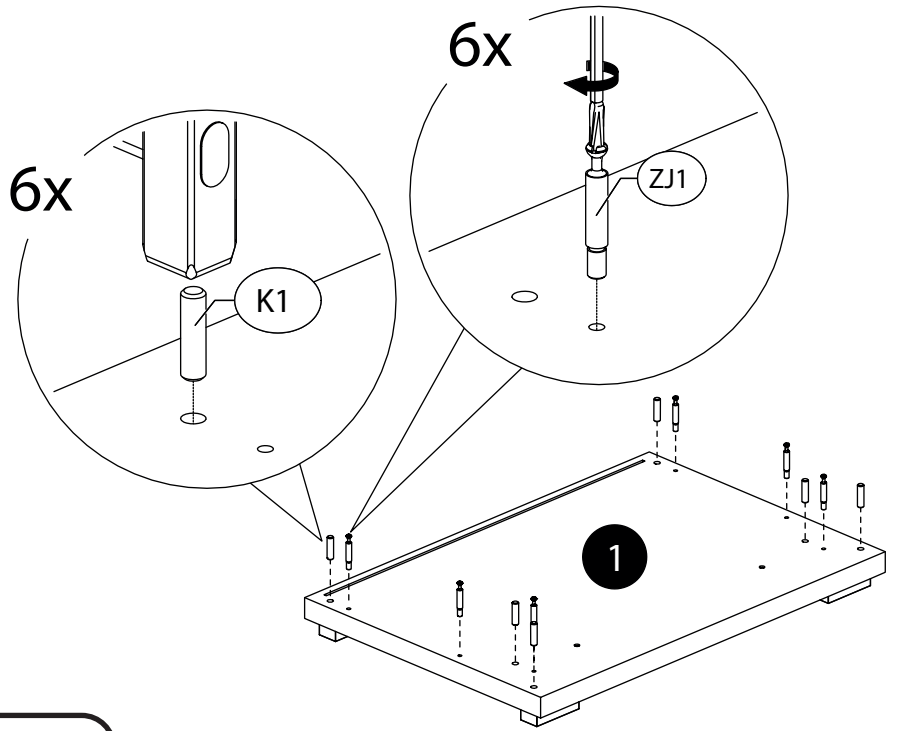
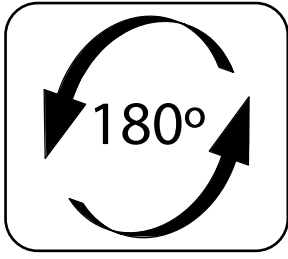

9.

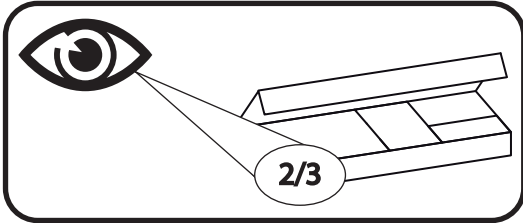

10.

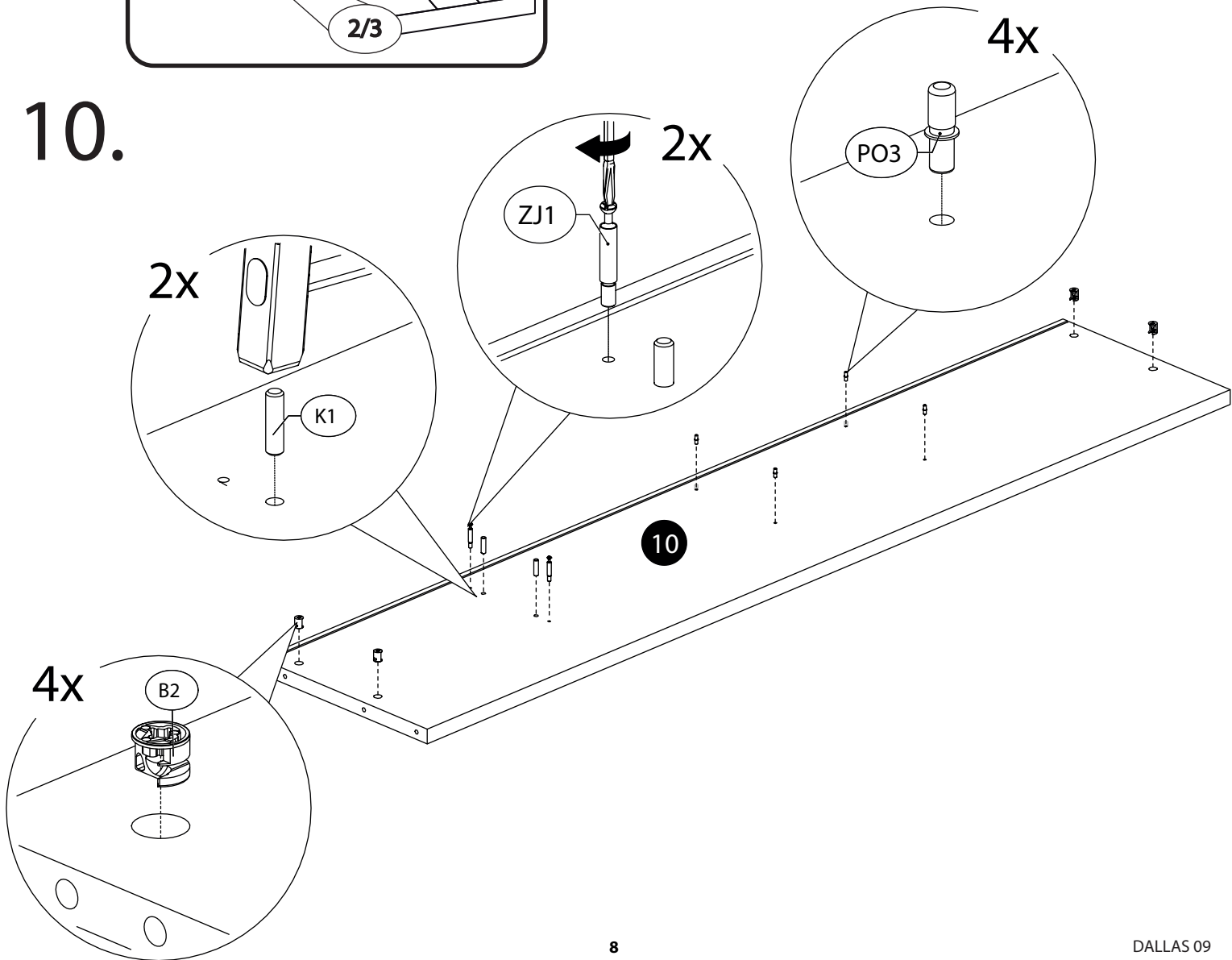

11.



P

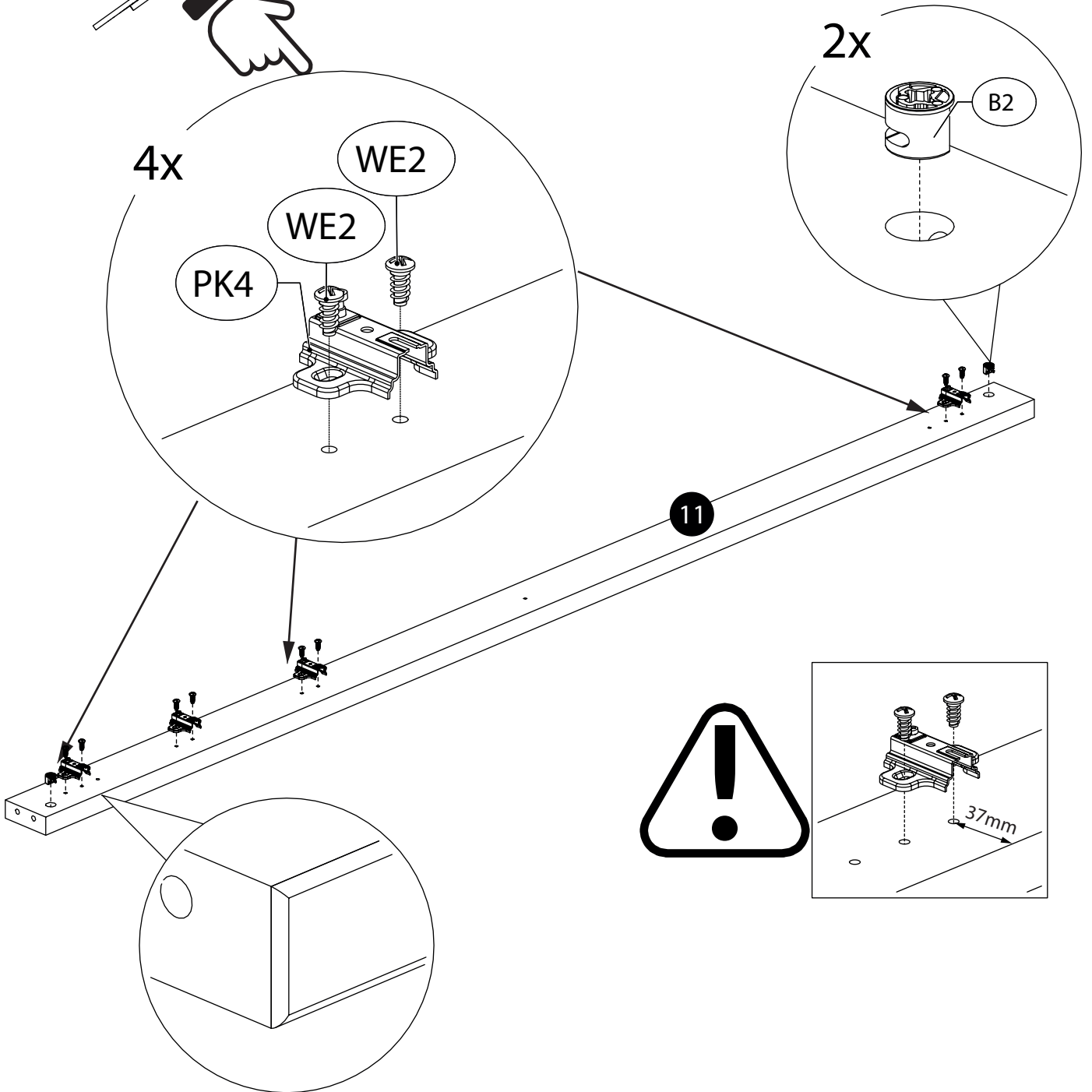

12.

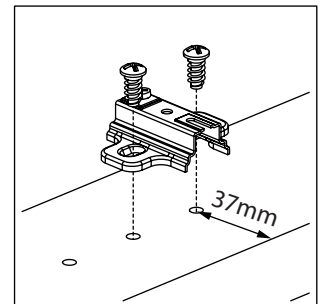
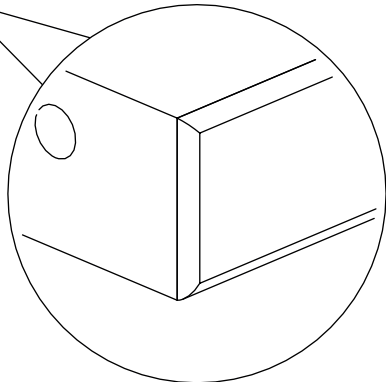
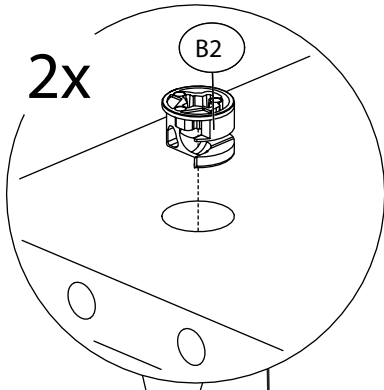
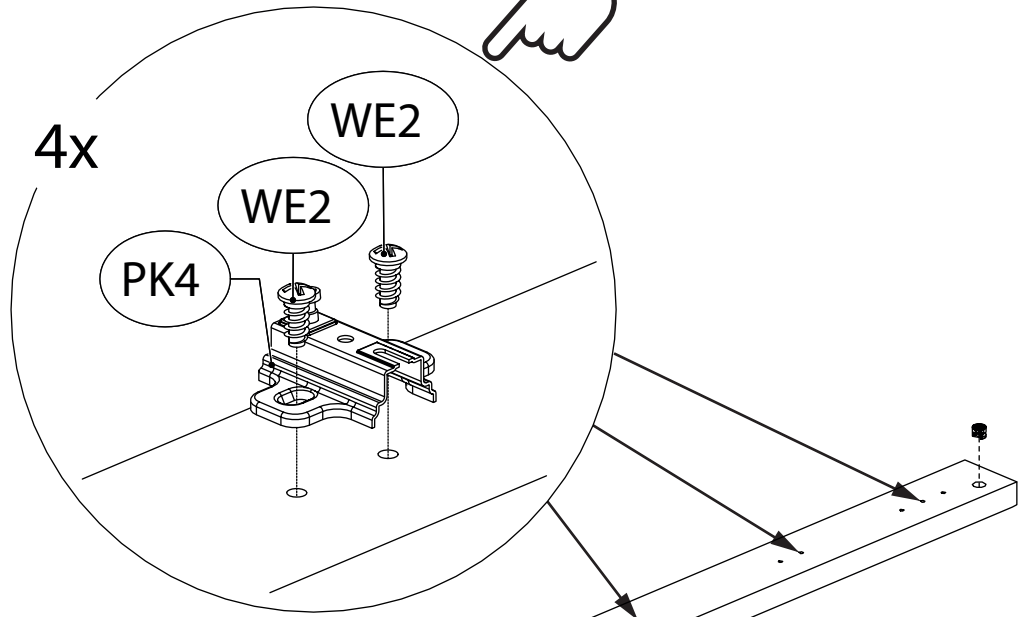
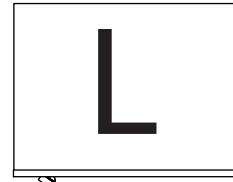

13.

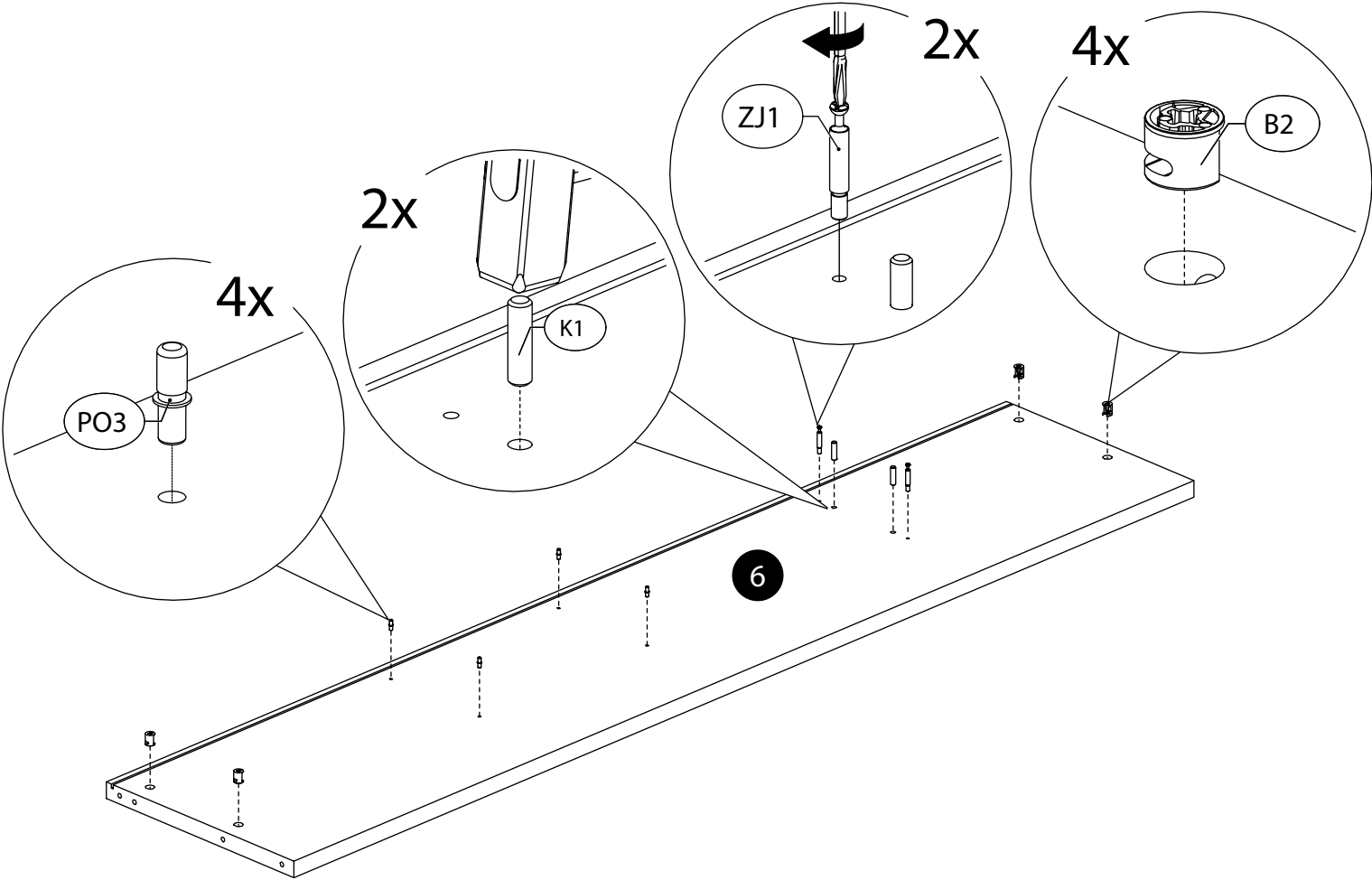

14.

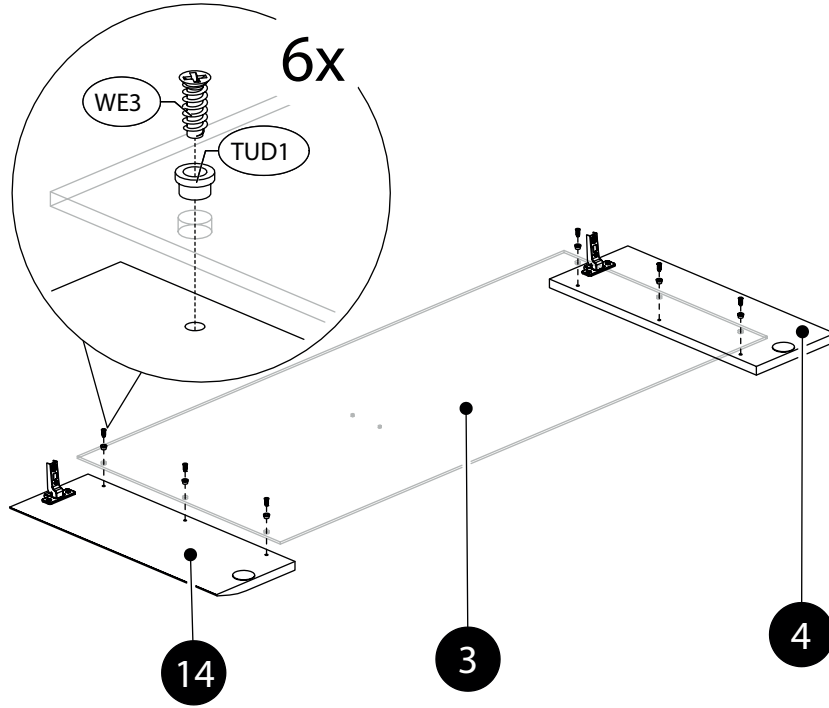

15.

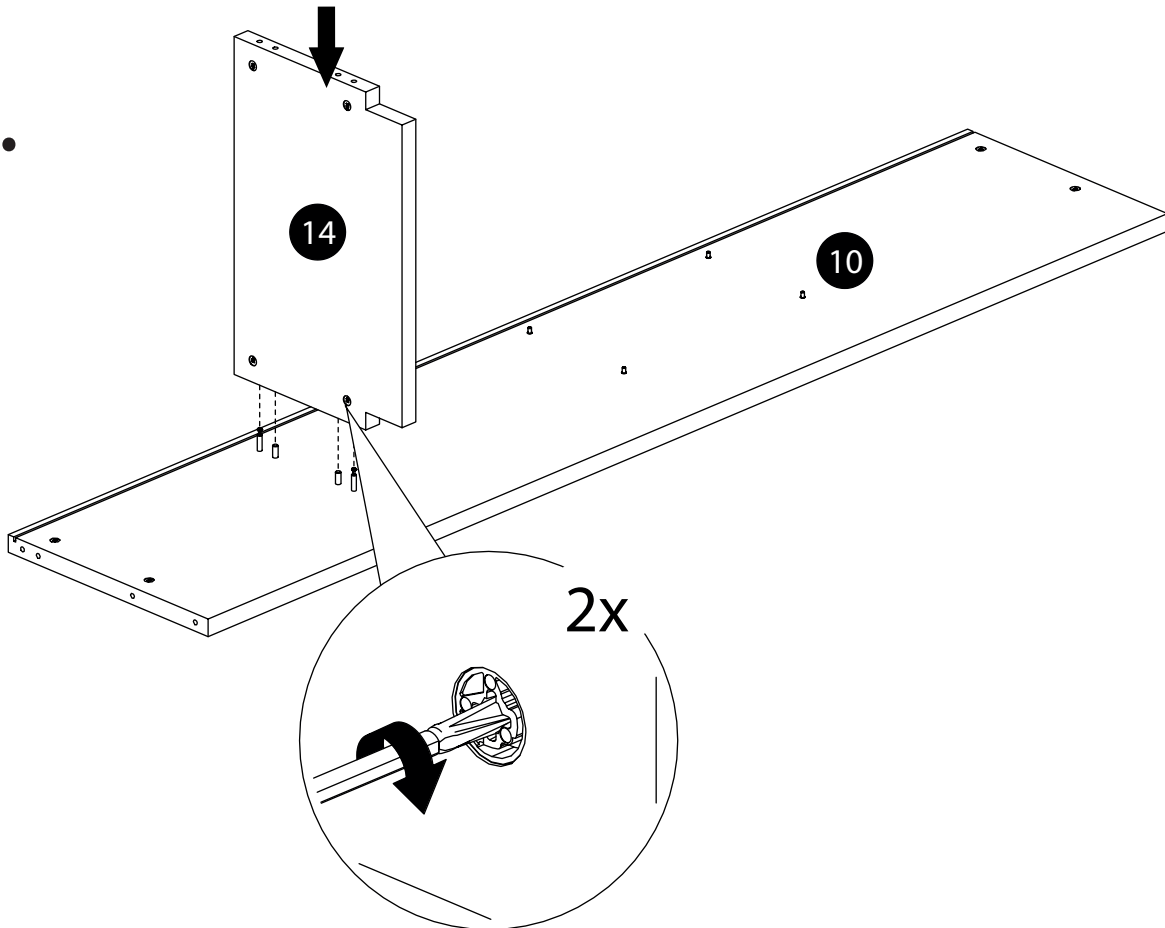

16.

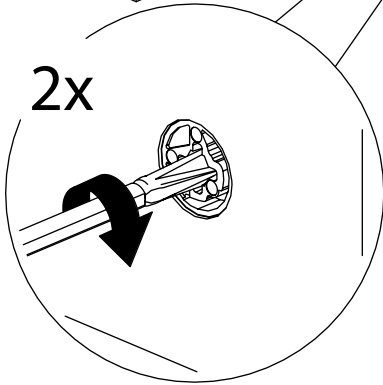
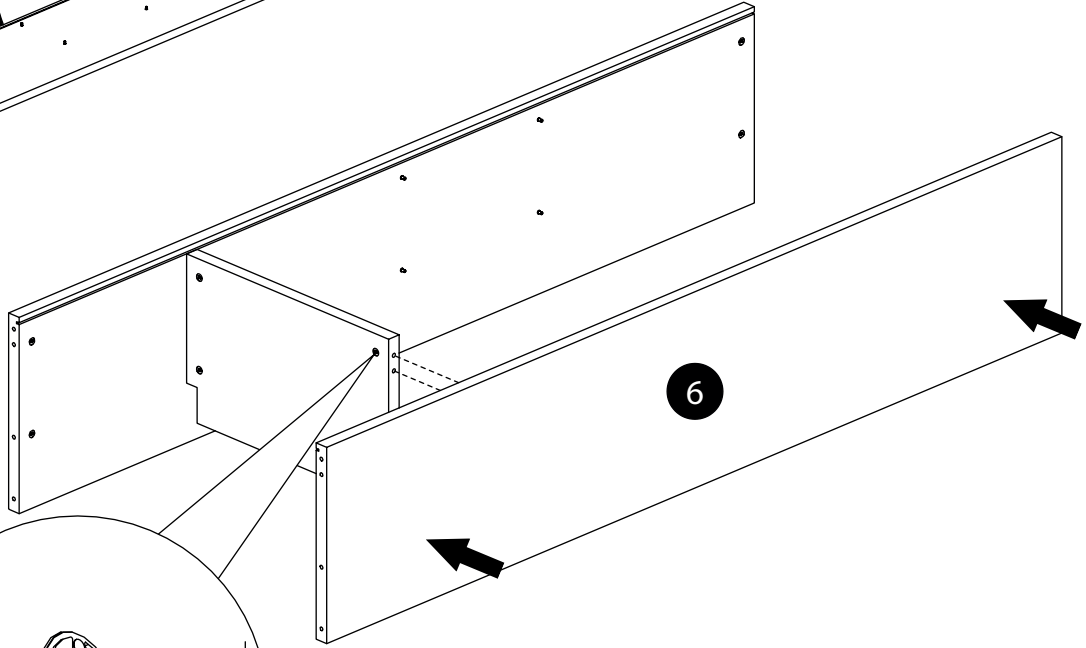
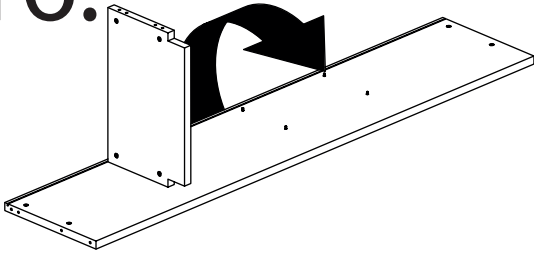

17.

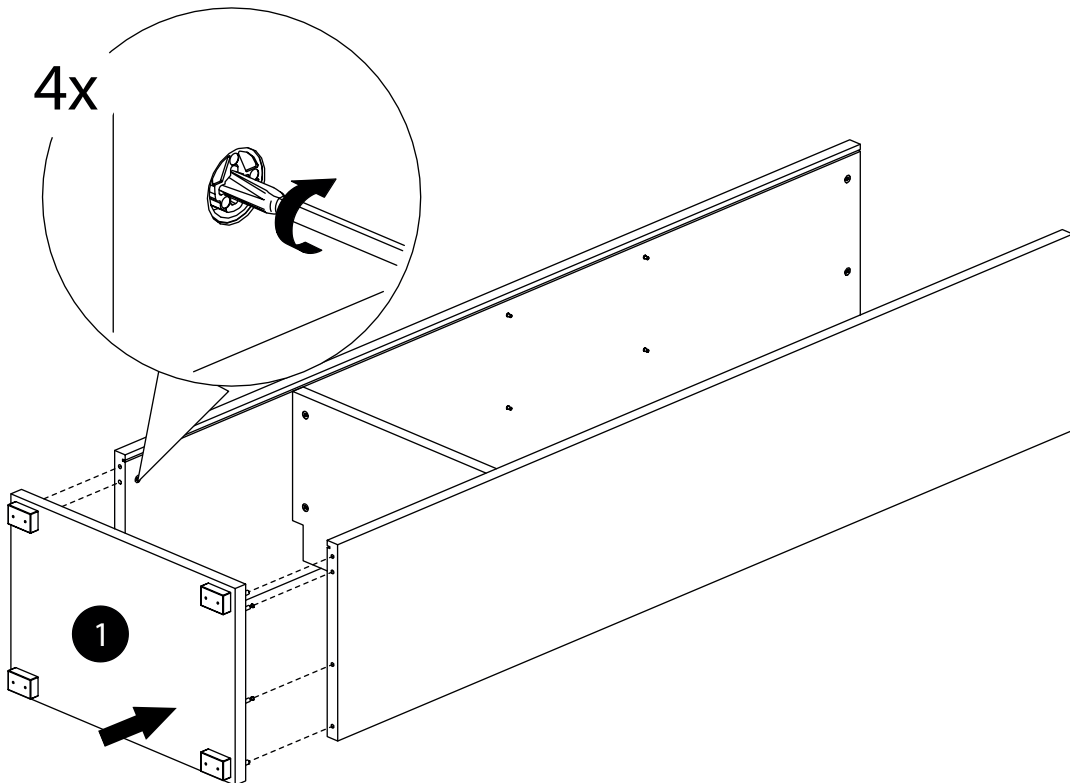

18.

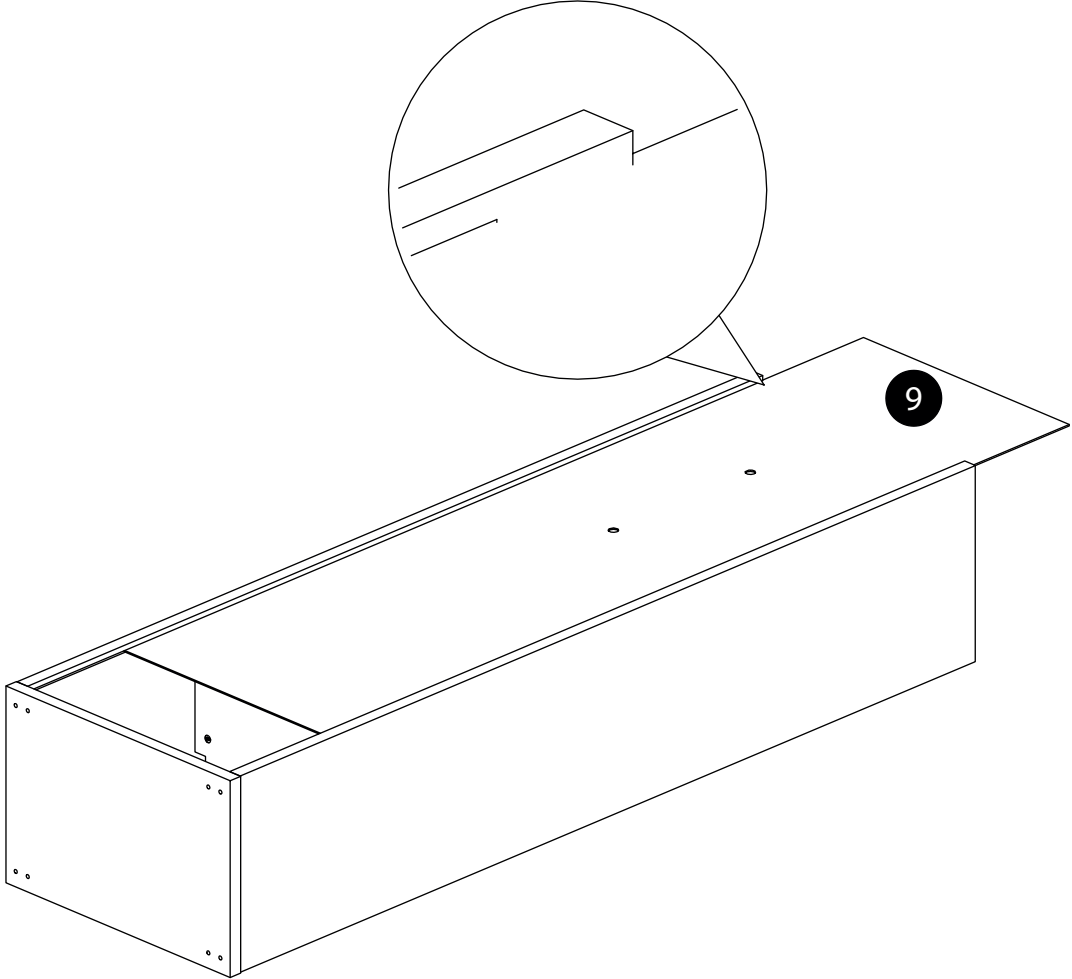

19.

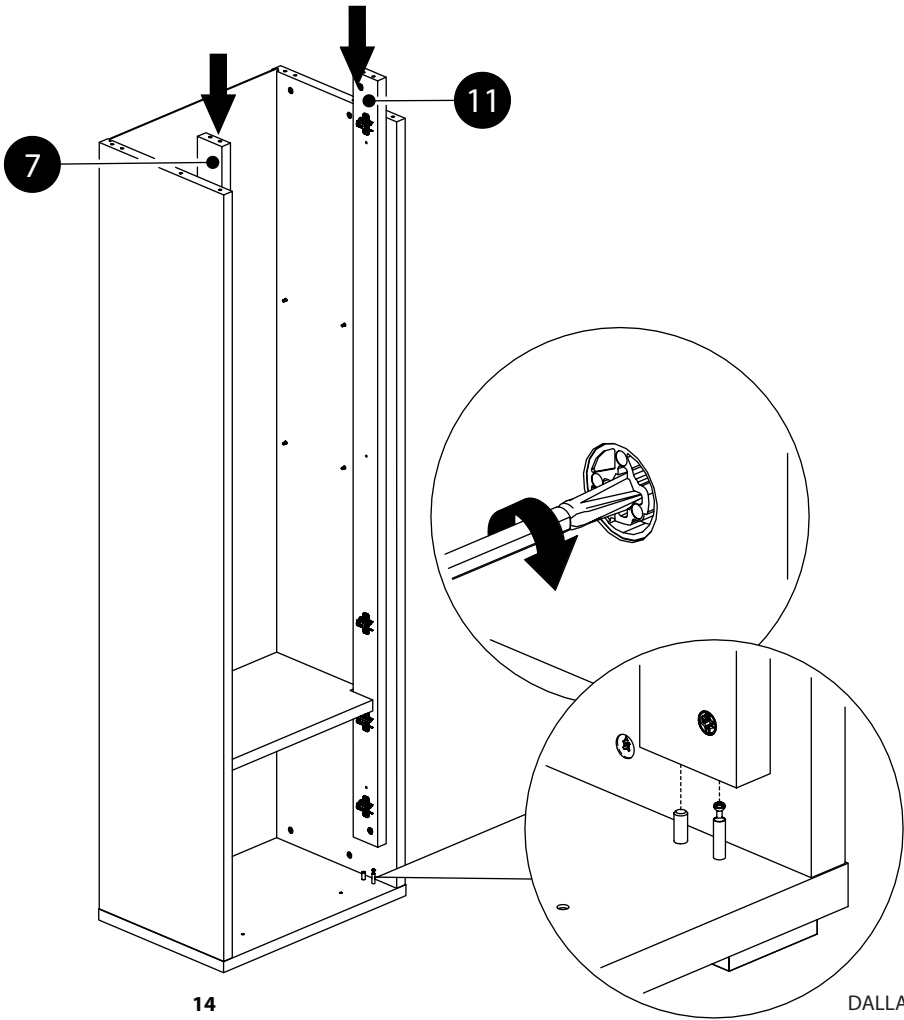
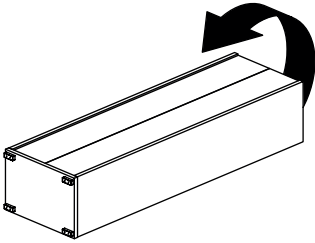

20.

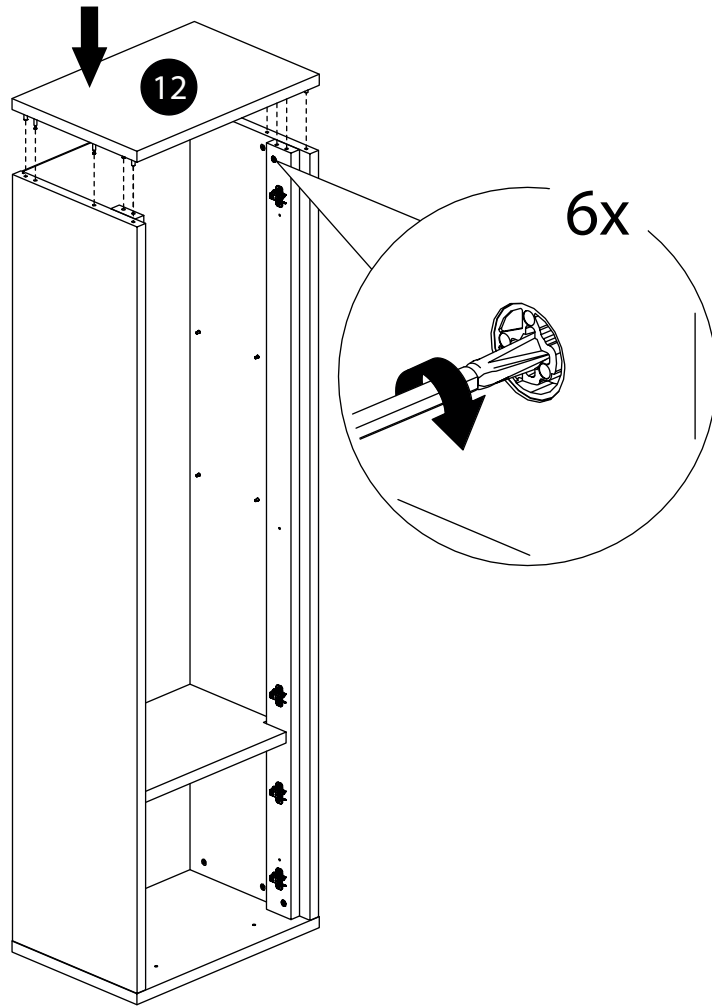

21.

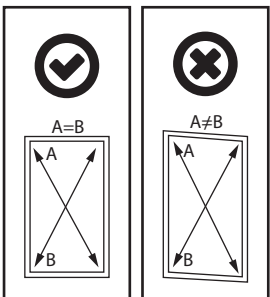
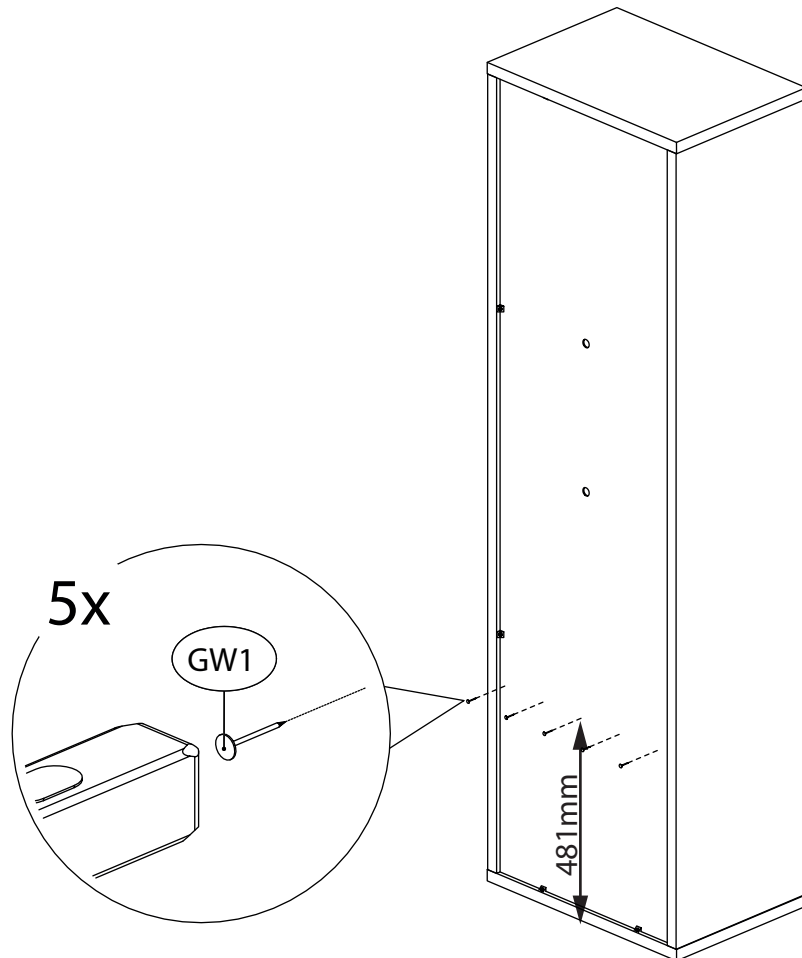
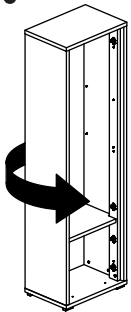

22.

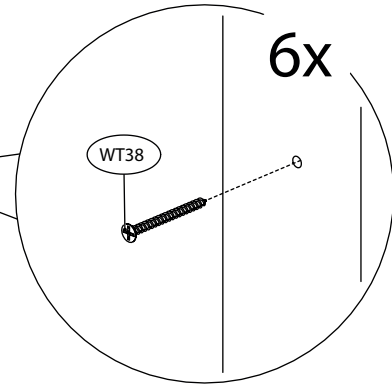
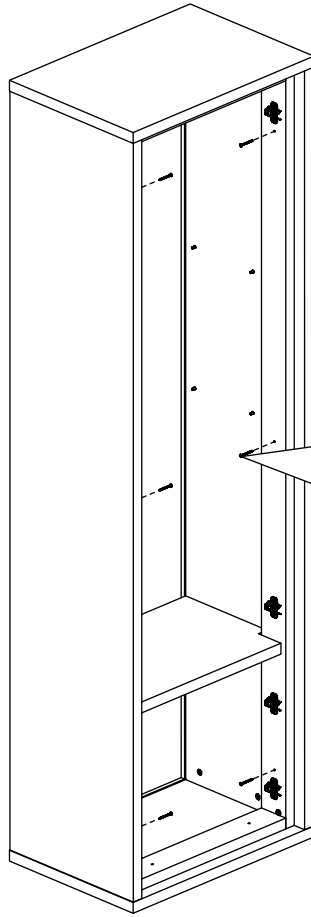
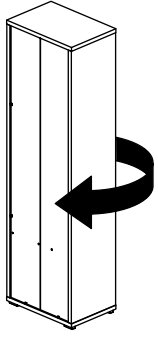

23.

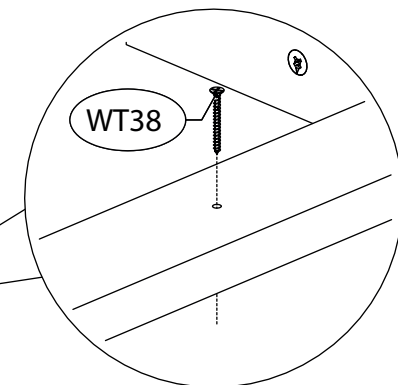
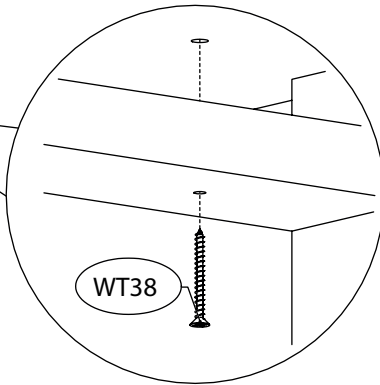
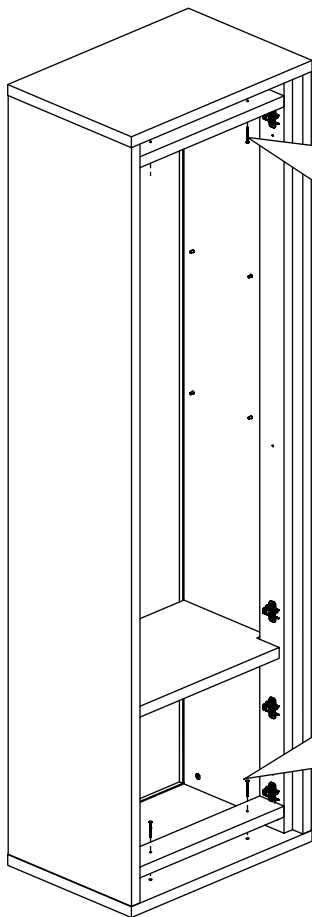

24.

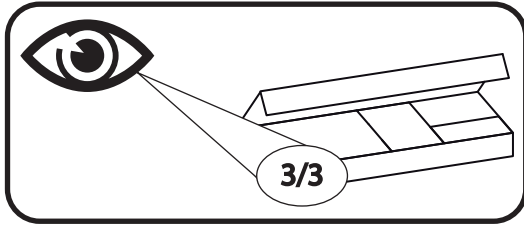

25.

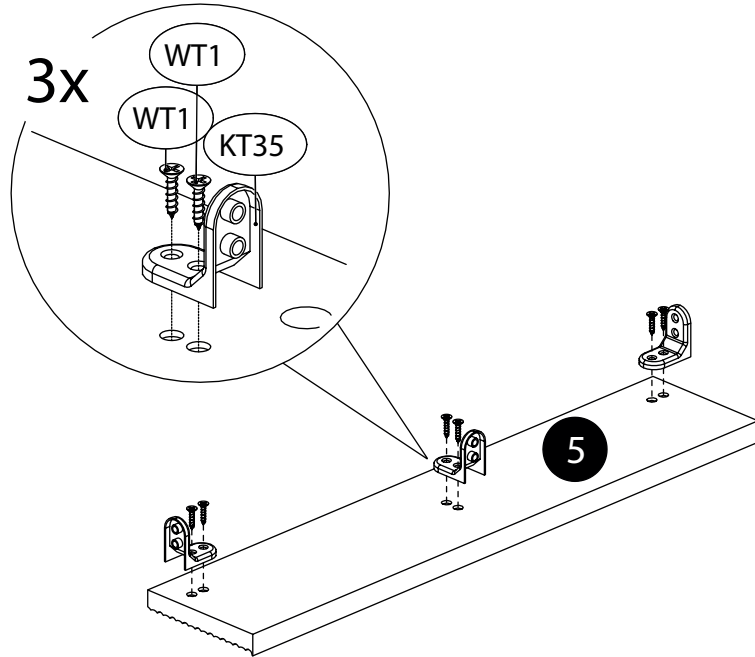

26.

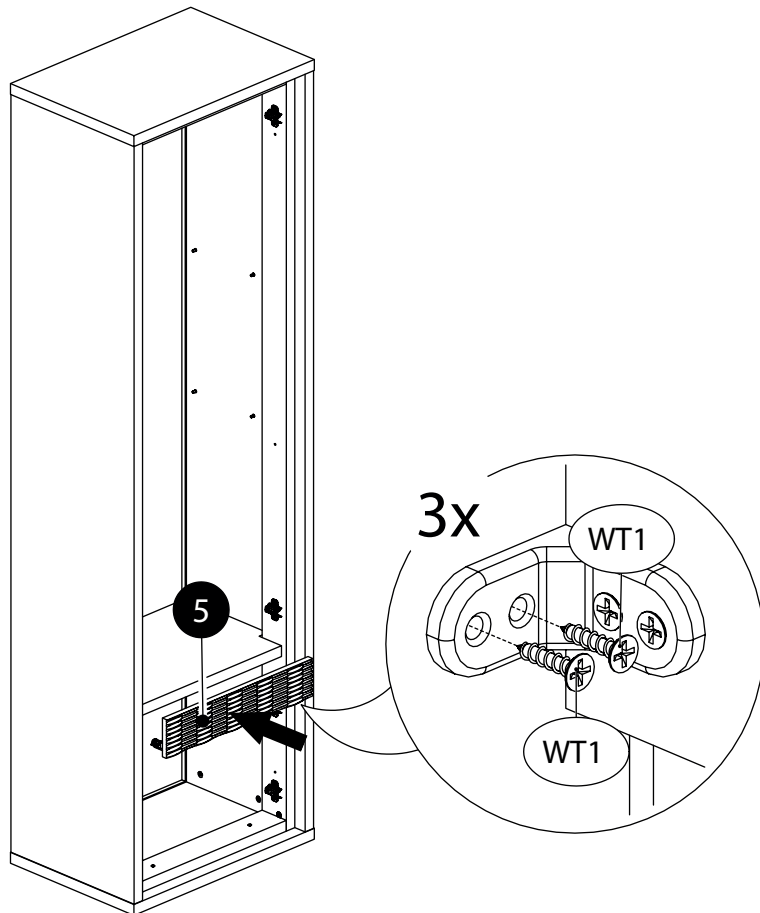

27.

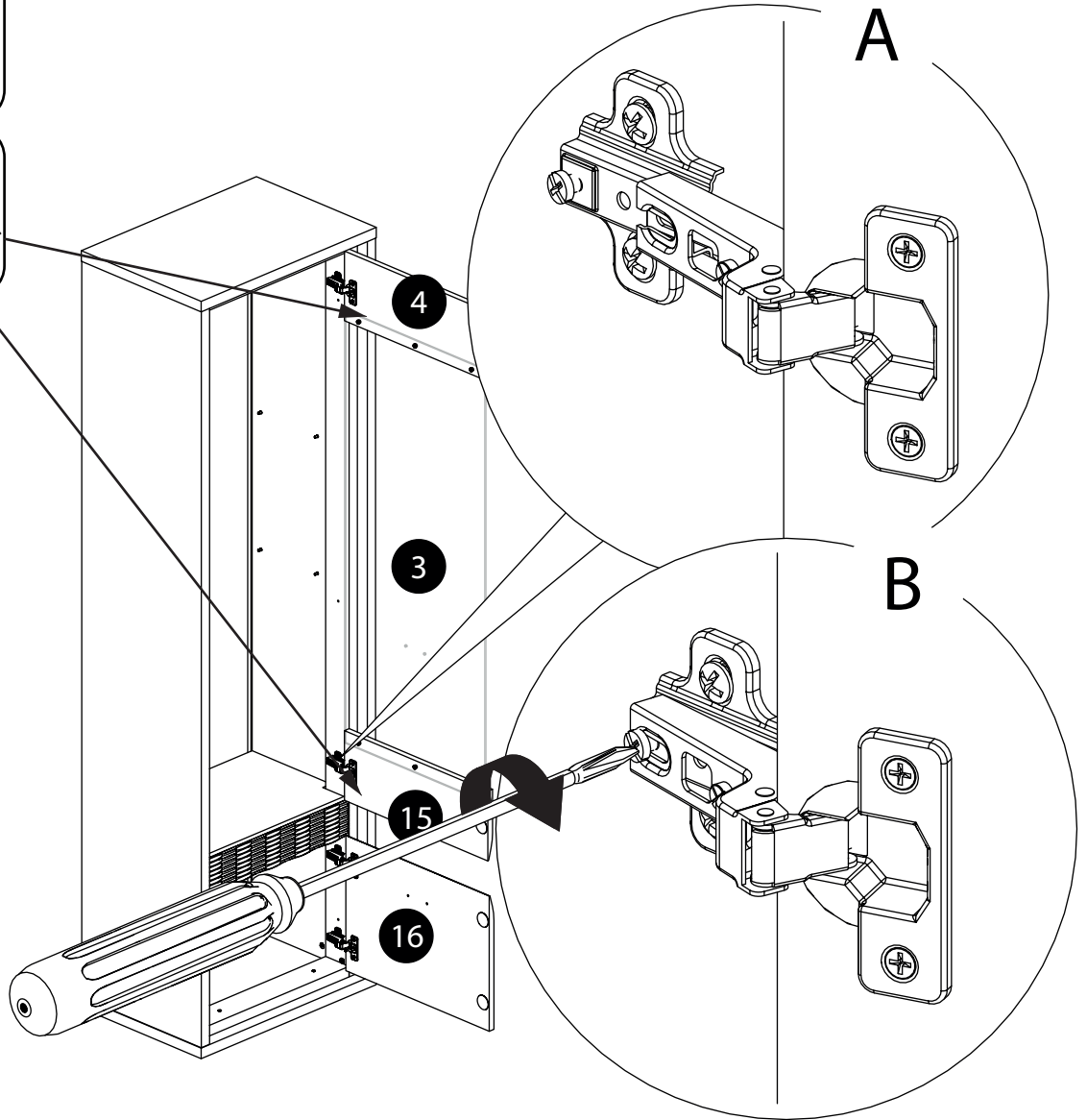

28.

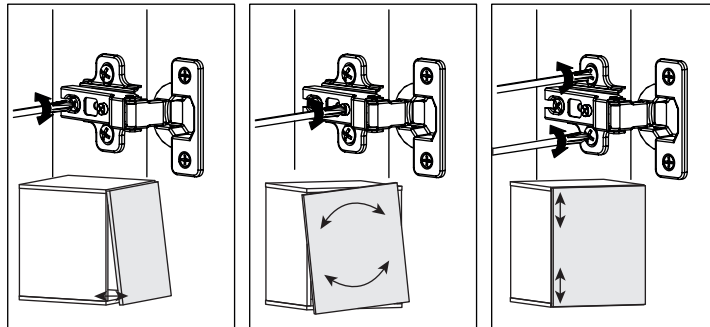

29.

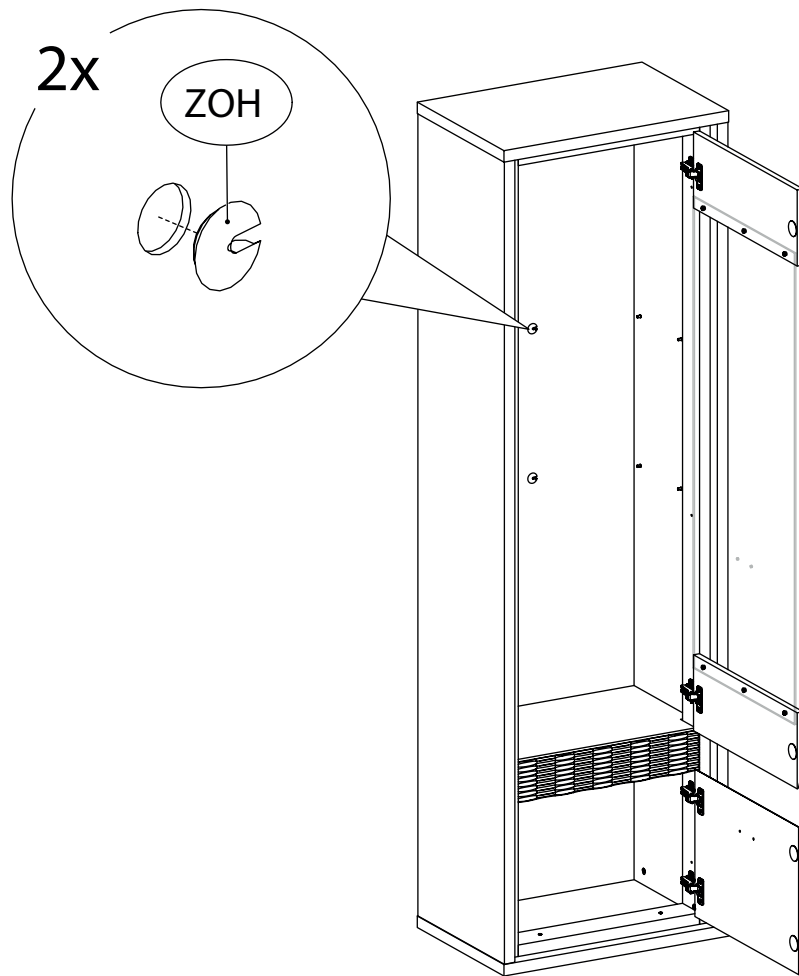

30.

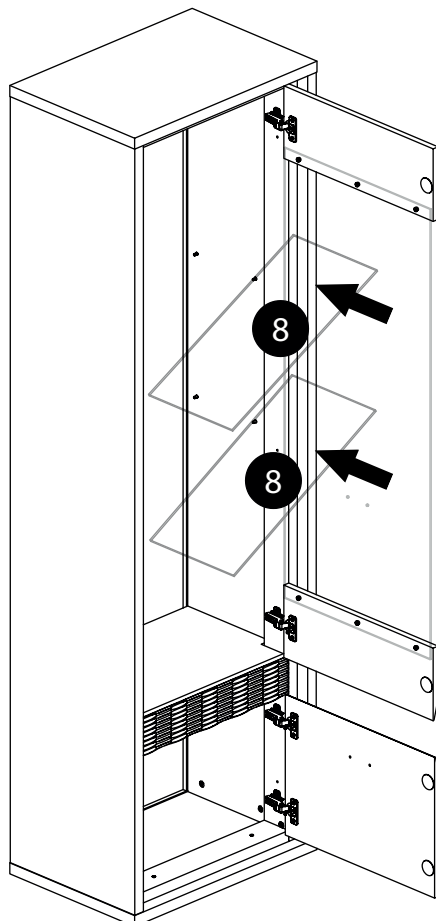

31.

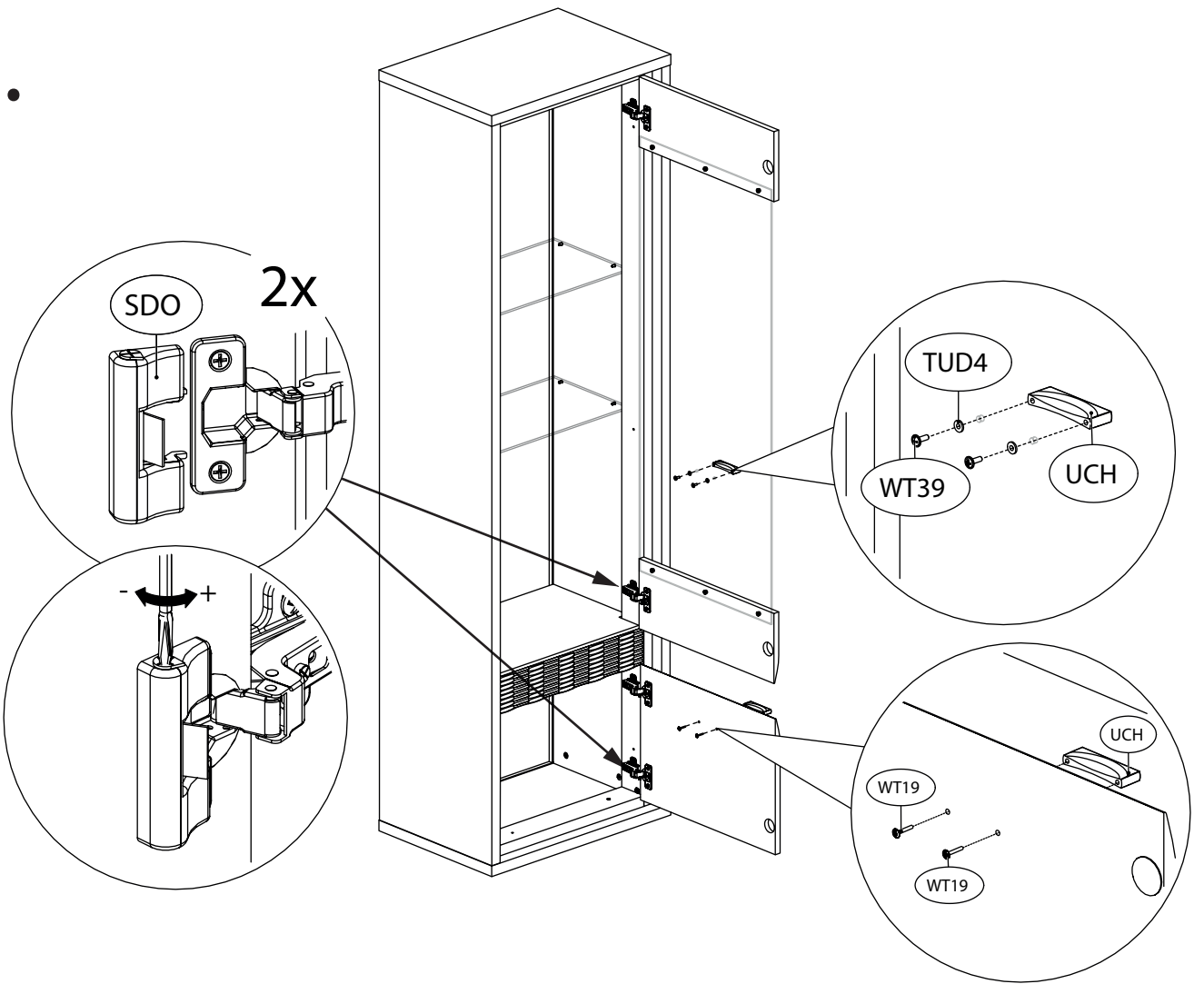

32.

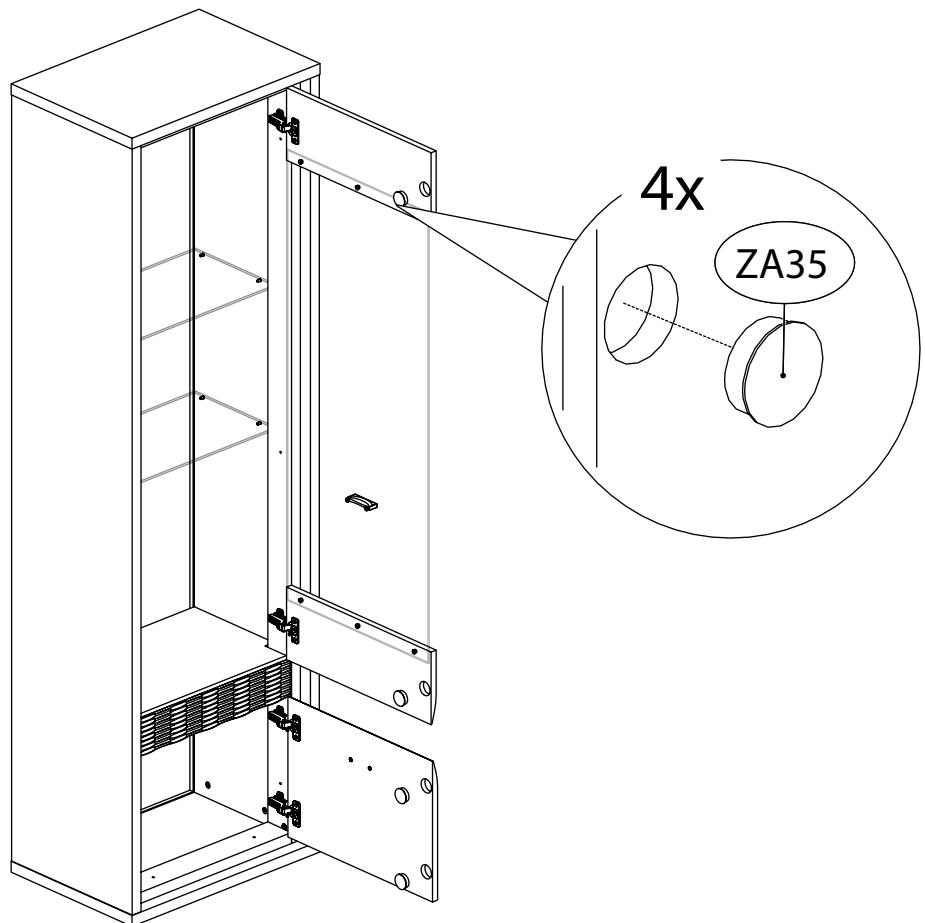

33.

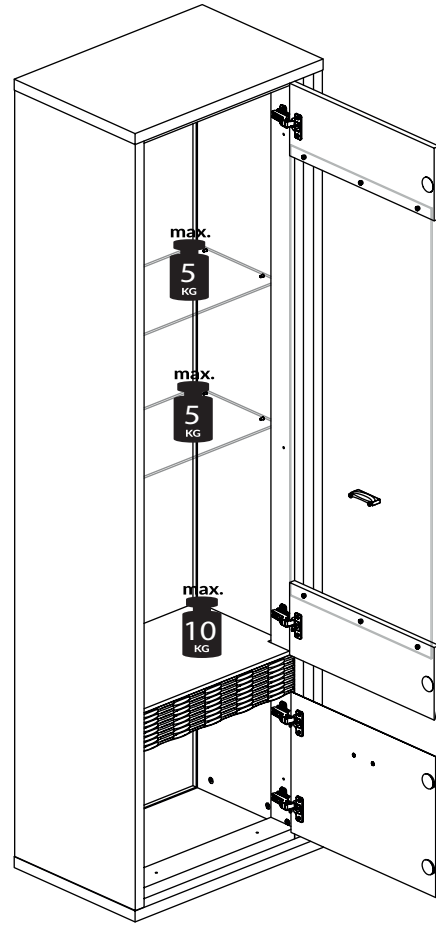
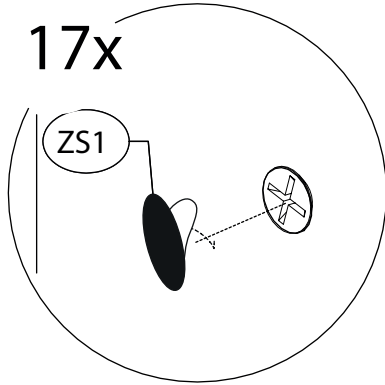
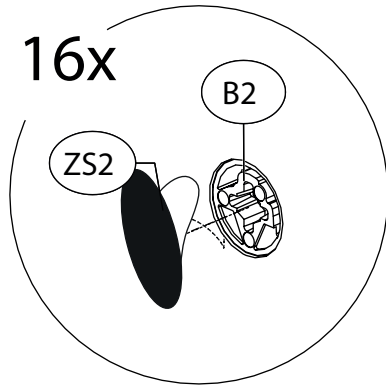

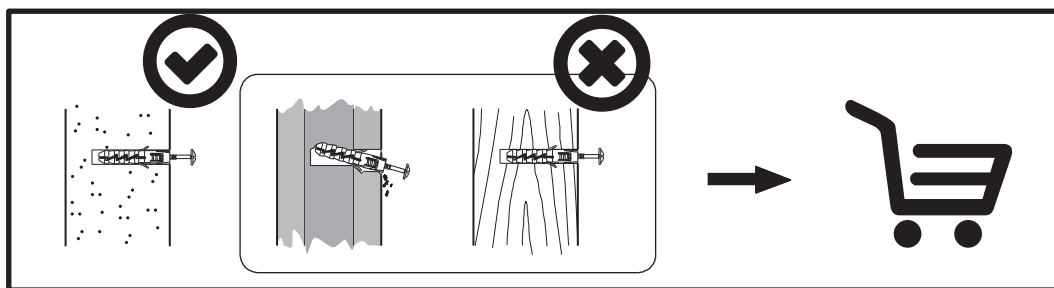

- PL -
Przed zawieszeniem mebla, lub przymocowaniem go do ściany (w celu zabezpieczenia przed przewróceniem), sprawdź wcześniej rodzaj i wytrzymałość ściany. Dobierz odpowiednie kołki i wkręty do rodzaju ściany. W przypadku wątpliwości skontaktuj się ze specjalistą. Montaż musi zostać wykonany przez osobę kompetentną.

UWAGA!!! Jeżeli do wyrobu są dołączone kołki rozporowe z wkrętami, to są one przeznaczone tylko i wyłącznie do ścian wykonanych z litych i jednorodnych materiałów.

- RU -
Перед подвешиванием мебели или ее креплением к стене (для защиты от падений) проверьте предварительно тип и прочность стены. Подберите соответствующие типу стены дюбели и шурупы. При возникновении сомнений свяжитесь со специалистом. Монтаж должен проводиться компетентным лицом.

ВНИМАНИЕ!!! Если к изделию прилагаются распорные дюбели с шурупами, они предназначены исключительно для стен из литых и однородных материалов.

- CZ -
Před zavěšením nábytku nebo jeho připevněním ke zdi (za účelem zajištění před převrácením) dříve zkontrolujte druh a odolnost stěny. Vyberte k druhu stěny vhodné hmoždinky a šrouby. V případě pochybností kontaktujte specialistu. Montáž musí být provedena kompetentní osobou.

POZOR!!! Pokud jsou k výrobku přiloženy hmoždinky se šrouby, jsou určeny jen a výhradně do stěn zhotovených z masivních a homogenních materiálů.

- SK -
Pred zavesením nábytku alebo jeho pripavením na stenu (za účelom zaistenia pred prevrátením) predtým skontrolujte druh a odolnosť steny. Vyberte k druhu steny vhodné hmoždinky a skrutky. V prípade pochybností kontaktujte špecialistu. Montáž musí byť vykonaná kompetentnou osobou.

POZOR!!! Pokiaľ sú k výrobku priložené hmoždinky so skrutkami, sú určené len a výhradne do stien zhotovených z masívnych a homogénnych materiálov.

- EN -
Before suspending or fixing furniture to the wall (in order to prevent falling over), check the type and strength of the wall. Select wall plugs and screws appropriate for the given type of the wall. In the case of doubts, contact a specialist. The installation must be performed by a competent person.

WARNING!!! If the rawlplugs with screws are attached to the product, then they are intended only for walls made of solid and homogeneous materials.

- HU -
A bútor felfüggesztése illetve falhoz való rögzítése (megakadályozván ezzel eldőlésének lehetőségét) előtt ellenőrizze a fal fajtaját és szilárdságát. Megfelelő, a falhoz illő tipliket és csavarokat használjon. Ha kétsége támadna, konzultáljon szakemberrel. A felszerelést csakis egy hozzáértő szakember végezheti el.

FIGYELEM!!! Ha a termékhez tipliket és csavarokat mellékelünk, akkor ezeket csakis tömör és homogén anyagból készült falakhoz szabad használni.

- DE -
Bevor Sie ein Möbelstück an einer Wand aufhängen oder befestigen (um es gegen Umkippen zu sichern), prüfen Sie Art und Tragfähigkeit der Wand. Wählen Sie die für die Wand geeigneten Dübel und Schrauben. Im Zweifelsfall kontaktieren Sie bitte einen Fachmann. Die Montage muss durch eine sachkundige Person ausgeführt werden. ACHTUNG!!! Wenn der Ware Dübel und Schrauben beiliegen, sind sie ausschließlich zur Anwendung an Wänden aus massiven und einheitlichen Materialien bestimmt.

- BG -
Преди да закачите мебела, или преди да го прикрепите към стената (за да се предотврати

падането), проверете предварително вида и силата на стената. Използвайте дюбели и винтове подходящи за вида на стената. В случай на съмнение, консултирайте се със специалист. Монтажът трябва да бъде извършен от компетентно лице.

ВНИМАНИЕ!!! Ако с продукта са доставени дюбели и винтове, те са предназначени единствено за стени, изработени от твърди и еднородни материали.

- FR -
Avant de suspendre le meuble ou de le fixer au mur (dans le but d'éviter un renversement), vérifiez au préalable le type et la résistance du mur. Utilisez les chevilles et les vis adaptées au type de mur. En cas de doute, veuillez contacter un spécialiste. Le montage doit être réalisé par une personne compétente.

ATTENTION !!! Si l'ensemble contient des chevilles avec des vis, elles sont adaptées uniquement pour les murs constitués de matériaux pleins et homogènes.

- TR -
Mobilyayı duvara asmadan veya montaj etmeden önce (devrilmesini önlemek için) duvarın türünü ve dayanıklılığını kontrol edin. Duvara uygun dübelleri ve vidaları seçin. Emin olamamanız durumunda bir uzman ile irtibata geçin. Kurulum yetkili bir kişi tarafından yapılmalıdır.

DIKKAT!!! Bir ürünü ile birlikte vidalar ve dübelleri verilirse, bunlar sadece kati ve homojen malzemelerden yapılmış duvarlara uygundur.

- ES -
Antes de colgar o fijar el mueble en el muro (a fin de proteger contra el vuelco del mueble), compruebe de antemano la naturaleza y la resistencia de la pared. Seleccione tacos y tornillos adecuados para el tipo de la pared. En caso de duda, consulte a un especialista, debiendo efectuar este montaje una persona competente.

¡¡¡ATENCIÓN!!! En caso el producto esté acompañado de tacos y tornillos, éstos se destinan solamente a los muros hechos con materiales sólidos y homogéneos.

- P -
Antes de pendurar ou fixar o móvel na parede (a fim de proteger contra a sua queda), verifique com antecedência a sua natureza e resistência. Selecione buchas e parafusos adequados para o tipo da parede. Em caso de dúvida, consulte um especialista. A montagem deve ser efetuado por uma pessoa competente.

ATENÇÃO !!! Se o produto for acompanhado de buchas e parafusos, estes destinam-se só às paredes feitas com materiais sólidos e homogéneos. hh

- SLO -
Pred montažo pohištvá na steno ali pritrditve le-tega k steni (v cilju preprečitve, da se ne prevrne) prej preverite vrsto in močnost stene. Izberite vložke in vijake, ki odgovarjajo vrsti stene. V primeru dvomov se posvetujte s specialistom. Montažo sme opraviti izključno ustrezno kvalificirana oseba.

POZOR!!! Če so k izdelku priloženi razporni vložki z vijaki, so le-ti namenjeni samo in izključno za montažo na stene, izdelane iz masivnih in homogenih materialov.

- NL -
Voordat u het meubel ophangt of bevestigt tegen de muur (om het te beschermen tegen omvallen) dient u het type en de duurzaamheid van deze muur na te kijken. Maak gebruik van pluggen en schroeven die geschikt zijn voor het type muur. Neem in geval van twijfels contact op met een specialist. De assemblage dient te worden uitgevoerd door iemand met kennis van zaken.

OPGELET!!! Indien u kunt kiezen uit bijgevoegde pluggen met schroeven, dan zijn deze uitsluitend bestemd voor muren van massieve, homogene materialen.

- SRB -
Pre vešanja nameštaja, ili pričvršćivanja ga do zida (radi osiguranja od prevrtanja), treba unapred proveriti vrstu i izdržljivost zida. Treba birati odgovarajuće ekseri e vijke prema određenoj vrsti zida. U slučaju sumnje kontaktirati se sa stručnjakom. Montažu mora izvršiti kompetentno lice.

NAPOMENA!!! Ukoliko uz proizvod priloženi su rastezni ekseri sa vijcima, to su oni namenjeni samo i isključivo za zidove izrađene iz čvrstih i jednorodnih materijala.

- RO -
Înainte de suspendarea unei piese de mobilier sau atașarea acestuia la perete (pentru a preveni bascularea), verificați în prealabil tipul și gradul de rezistență a peretelui. Montați diblurile și șuruburile adecvate pentru tipul de perete. În caz de îndoieli, consultați un specialist. Instalarea trebuie să fie efectuată de către o persoană competentă.

ATENȚIE!!! Dacă un produs este livrat împreună cu dibluri cu șuruburi, înseamnă că este proiectat sunt proiectate exclusiv pentru pereți realizați din materiale solide și omogene.

- HR -
Prije kačenja nameštaja ili montaže na zidu (u cilju zaštite od prevrtanja), provjerite vrstu zida i njegovu otpornost. Izaberite odgovarajuće šarfove i uvijače za određenu vrstu zida. U slučaju nejasnoća, kontaktirajte stručnjaka. Montažu treba vršiti stručno lice.

PAŽNJA !!! Ako uz proizvod su uključeni šarfovi, znači to da su oni namjenjeni samo za zidove napravljene od jedne vrste materijala.

- S -
Innan möbelen hängs upp eller förankras i väggen (så att den inte välter), kontrollera först hur väggen är uppbyggd och hur mycket den kan belastas. Välj sedan lämplig väggplugg och skruv. Om du är osäker ta kontakt med en specialist. Montage måste utföras av kompetent person.

OBS!!! Om produkten levereras med väggplugg och skruv är de avsedda endast till väggar av kompakt homogent material.

- I -
Prima di appendere i mobili, oppure attaccarli al muro (per proteggerli da ribaltamenti), verifica prima la tipologia e resistenza del muro. Scegli i tasselli e viti più adatti per il tipo di muro. In caso di dubbi contattare uno specialista. Il montaggio deve essere fatto da una persona competente.

ATTENZIONE!!! Se viti e tasselli sono inclusi nell'offerta, essi sono utilizzabili solamente per i muri fatti di un certo tipo di materiale.

- UKR -
Перед підвішуванням меблів або їх кріпленням до стіни (з метою захисту від падіння) перевірте попередню тип та міцність стіни. Підберіть відповідні типу стіни дюбелі та шурупі. При наявності сумнівів зв'яжіться зі спеціалістом. Монтаж повинен проводитися компетентною особою.

УВАГА!!! Якщо до виробу додаються розпирні дюбелі з шурупами, вони призначаються виключно для стін з литих та однорідних матеріалів.

- LT -
Norint pakabinti baldus (arba pritvirtinti prie sienos), reikia patikrinti sienos kokybę ir stiprumą. Reikia pasirinkti varžtus tinkamus sienos tipui. Kilus klausimams raginame kreiptis į specialistus. Montavimą turi atlikti kompetentingas asmuo.

DĖMESIO!!! Varžtai pateikti su baldais yra skirti tik vientisų medžiagų pastatytams sienams.

- LV -
Pirms pakarat, piestiprināt mēbeļi pie sienas (lai to aizsargātu pret apgāšanos), pārbaudiet sienas veidu un nestspēju. Izvēlieties sienas veidam atbilstošus dibeljus un skrūves. Šaubu gadījumā sazinieties ar speciālistu. Montaža jāveic kvalificētai personai.

UZMANĪBU!!! Ja izstrādājumam ir pievienoti dibelji ar skrūvēm, tie ir paredzēti tikai un vienīgi sienām, kas izgatavotas no cietiem un viendabīgiem materiāliem.

- EST -
Enne mööbli riputamist või kinnitamist seinale (ümbermineku tõkestamiseks), tuleks enne uurida seinale olemust ja tugevust. Paigaldada tüüblid ja kruvid vastavalt seinale. Kahtluse korral konsulteeruda spetsialistiga. Paigaldus

